

Z-Series

Z310 CD Player

Owner's manual

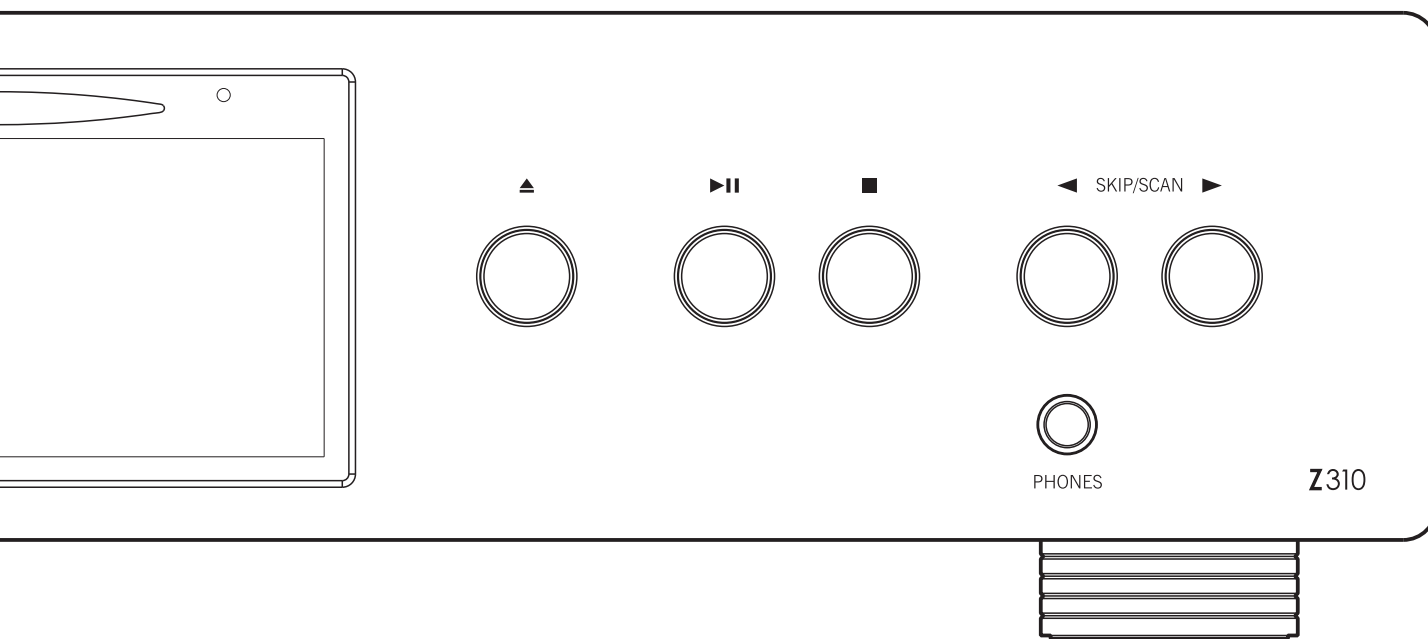

CONTENTS

• Introduction	2
• Installation and Safety	2
• Accessories	2
• Setting up your CD player	3
Rear panel connections	
• Operating your CD player	4
Front panel controls	
• Remote Control	6
• Care and handling of compact discs	7
• Installing and replacing batteries in the remote control	7
• Trouble-shooting guide	7
• Specifications	7

INTRODUCTION

The Myryad Z310 has been designed to offer a combination of high quality sound reproduction and elegant styling in keeping with other Myryad Z-Series products.

The Z310 is a full-function remote-controlled CD player. It has fixed-level low-impedance audio outputs to drive a Myryad integrated amplifier or pre-amplifier - or other high quality amplifier. In addition it has a digital output on a single RCA phono socket (SPDIF standard), suitable for feeding a digital recorder or processor.

INSTALLATION AND SAFETY

This CD player generates very little heat but still requires some ventilation. Do not place it on a rug or other soft surface into which it could sink, obstructing the air inlets in its underside. Do not allow any obstruction to the ventilation slots in the rear panel. The CD player should not be installed in a built-in situation such as a bookcase or rack unless proper ventilation is provided.

CAUTION: THIS APPARATUS MUST NOT BE EXPOSED TO DRIPPING OR SPLASHING. OBJECTS FILLED WITH LIQUIDS SUCH AS VASES MUST NOT BE PLACED ON THE APPARATUS.

THE REAR PANEL POWER SWITCH DISCONNECTS MAINS LIVE ONLY. THE POWER CORD MUST BE DISCONNECTED FROM THE REAR OF THE APPARATUS, OR THE WALL SOCKET, TO PROVIDE TOTAL ISOLATION. ONE OR OTHER OF THESE CONNECTIONS MUST BE READILY ACCESSIBLE WHEN THE APPARATUS IS IN USE.

Do not remove the cover, or attempt to modify or repair the CD player yourself. Refer all servicing to a qualified technician.

The CD laser radiation is Infra-Red, so you cannot see it. If the cover is removed for any reason, you **MUST** pay attention to the following warning.

CAUTION - INVISIBLE LASER RADIATION WHEN OPEN. DO NOT STARE INTO BEAM OR VIEW DIRECTLY WITH OPTICAL INSTRUMENTS.

ACCESSORIES

Your Z310 is supplied complete with the following accessories:

- Mains Cable
- MSR1 Remote
- Owner's Manual

SETTING UP YOUR CD PLAYER

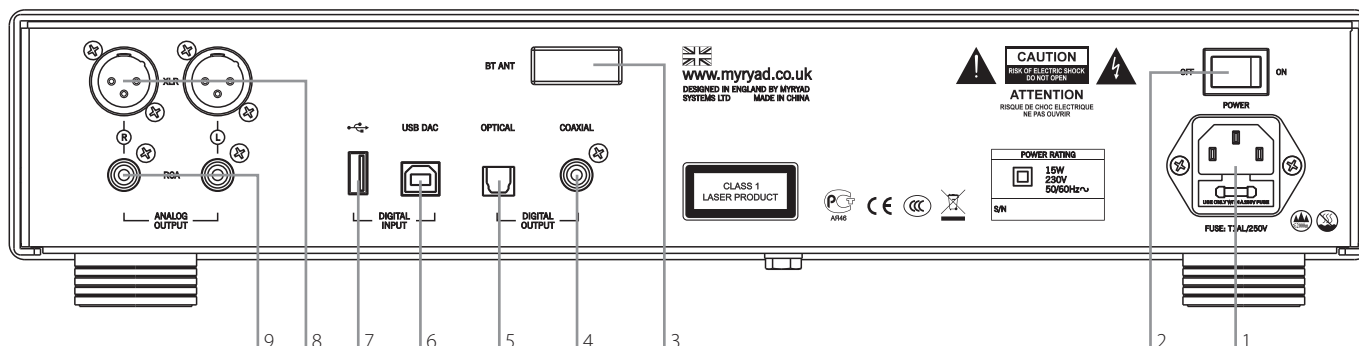

REAR PANEL CONNECTIONS

1. Power Inlet

Before making any connection, check that the mains voltage marked on the rear panel is the same as your local mains supply.

Plug the female (socket) end of the power cord into the power inlet on the rear of the CD player, making sure it is pushed in firmly. Plug the male (plug) end of the cord into a "live" wall socket or a suitable heavy-duty extension cable.

2. Power Switch

Press one side of this rocker switch (the side nearer the edge of the rear panel) to switch the CD player ON and the other side (towards the output sockets) to switch it OFF. When the POWER switch is in the OFF position all power is disconnected from the CD player. In this condition the CD player cannot be powered up from the front panel or the remote control. When the POWER switch is in the ON position (and the power cord correctly inserted and plugged in to a live wall socket) the CD player will power up in standby mode (see Front Panel Controls, STANDBY).

It is recommended that the POWER switch is turned OFF if the CD player is not going to be used for an extended period of time.

3. BT ANT

Receive for bluetooth signal.

4. Coaxial output

This is a serial electrical digital output to the "SPDIF" standard. It should be connected via a suitable interconnect to the SPDIF input of a separate DAC (Digital-to-Analogue-Converter), digital pre-amp or digital recorder. The cable should be of standard 75Ω impedance for best performance.

5. Optical output

This is a serial electrical digital output to the "SPDIF" standard. It should be connected via a suitable interconnect to the SPDIF input of a separate DAC (Digital-to-Analogue-Converter), digital pre-amp or digital recorder. The cable should be of standard 75Ω impedance for best performance.

6. USB DAC

Connect the audio output cables from a pc to these usb sockets.

7. USB disk input

USB for connecting external disk.

8. XLR output

Connect the audio input cables from a XLR to these sockets.

9. RCA output

Connect the audio input cables from a RCA to these sockets.

OPERATING YOUR CD PLAYER

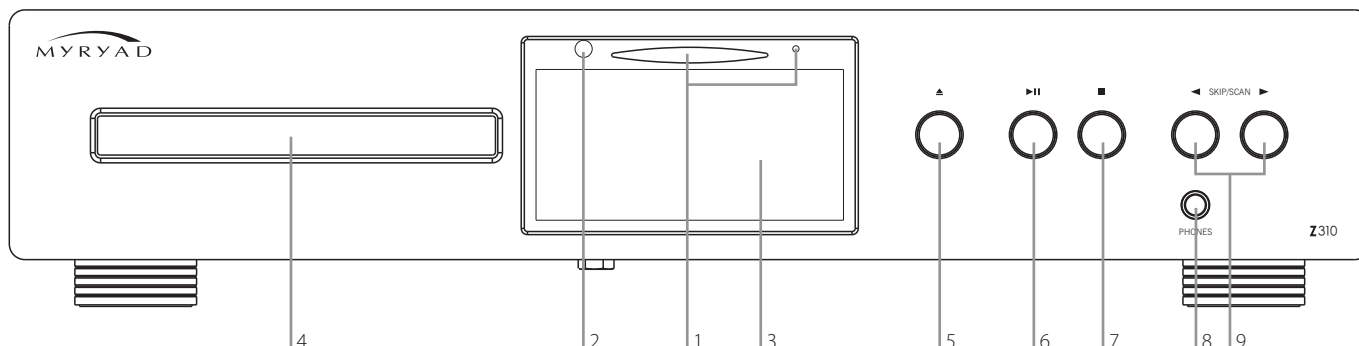

FRONT PANEL CONTROLS

1. Standby

When the player is plugged into a live wall socket and the POWER switch is turned ON, it will power up in “standby” mode and the LED (Light Emitting Diode) in the display will glow red. In this mode only a small part of the internal circuitry of the Z310 is powered up, so it consumes very little power and its inputs and outputs are isolated by relays.

When the STANDBY ellipse is touched (3 second) the Z310 circuitry will be activated, but the outputs will remain muted for a short period to allow the internal voltages to stabilise. During this delay period the LED on turns blue in the display and the display will indicate “MYRYAD”.

When the STANDBY ellipse is touched (3 second) again the player will be returned to standby mode. The standby LED will glow red again and the display will be extinguished.

CAUTION: WHEN IN STANDBY MODE THE INTERNAL CIRCUITRY IS STILL LIVE, SO ALL SAFETY PRECAUTIONS MUST BE FOLLOWED.

2. Infra-red receiver

The infra-red (IR) remote control receiver is mounted behind the window, just to the left of the display. It must not be obscured when the player is to be operated using the remote control handset.

Where possible it is best to arrange that the IR window is in “line-of-sight” of the remote handset.

3. Touchscreen

All functions accessible through multifunctional touch screen.

4. Disc drawer

The OPEN/CLOSE button controls the drawer. It will accept either normal 120 mm CDs, or small 80 mm CDs.

5. Open/Close ▲

Press this button to open or close the disc drawer. The drawer may also be closed by pushing the drawer front gently. When the drawer is open the display read “OPEN”. When the drawer is closed with no disc in the player the display will read “NO DISC”.

When a disc is inserted and the drawer closed the display will indicate “READ” briefly while it reads the disc’s Table of Contents (TOC). The display will then show the total number of tracks and total playing time of the disc. This condition is called STOP mode.

6. Play/Pause ►||

When a disc is present and the player is in STOP mode, a single press of the PLAY/PAUSE key will start the disc playing from the first track, and illuminate the ► symbol. When the disc is playing, pressing PLAY/PAUSE again will put the player in PAUSE mode and illuminate ||. In PAUSE mode the disc is still spinning and the laser head is kept at the same location, so that if PLAY/PAUSE is pressed yet again the disc will re-start from exactly the same point in the music at which it was originally paused.

7. Stop ■

When the STOP button is pressed the music stops playing, the disc stops spinning, the laser head is returned to the beginning of the disc is displayed. The player is now in STOP mode.

The player automatically returns to STOP mode when a disc has finished playing.

8. Headphone socket

The headphones socket will accept a standard 6.35mm stereo jack plug or adapter. All types of headphones of any impedance may be used, with one exception: electrostatic headphones are usually supplied with an adapter unit which must be connected directly to the loudspeaker terminals. Insertion of a plug into the headphones socket automatically disconnects the loudspeakers, silencing them. In order to resume listening to loudspeakers you must unplug the headphones from this socket. The headphones output is not muted when switching in and out of STANDBY mode, so it is recommended that headphones are unplugged from the player before switching to standby mode and plugged in again after switch-on.

9. Skip/scan ◀ ▶

The SKIP/SCAN keys are used to select the track, or section within a track, to be played. A brief press of one of these keys invokes the SKIP function. Pressing the key and holding it down continuously invokes the SCAN function.

While a disc is playing, pressing SKIP/SCAN ▶ briefly will cause the player to skip to the beginning of the next track. If SKIP/SCAN ◀ is pressed once, the player will skip to the beginning of the current track. If SKIP/SCAN ◀ is pressed twice in quick succession the player will skip to the beginning of the previous track. Repeated pressing of SKIP/SCAN ▶ or ◀ will make the player skip forward or back over any number of tracks. When playing the last track of a disc, SKIP ▶ will “wrap around” to track 1 (and similarly, SKIP ◀ from track 1 will skip to the last track). The SKIP keys have the same function in PAUSE mode. The SKIP function may also be used in STOP mode to select a track number. The selected track will play automatically shortly after the last key press.

The SCAN function is used to select a specific passage within a music track. While a disc is playing, pressing SKIP/SCAN ► or ◀ and holding it down continuously will cause the laser to scan rapidly forward (or backward) through the music. Snatches of music will be heard through the loudspeakers at a reduced volume level. If the SKIP/SCAN key is held down longer the player will scan faster, but there will be no sound from the loudspeakers.

It is not possible to SCAN back before the beginning of track 1, or SCAN forward after the end of the last track. The SCAN function does not operate in PAUSE mode.

REMOTE CONTROL

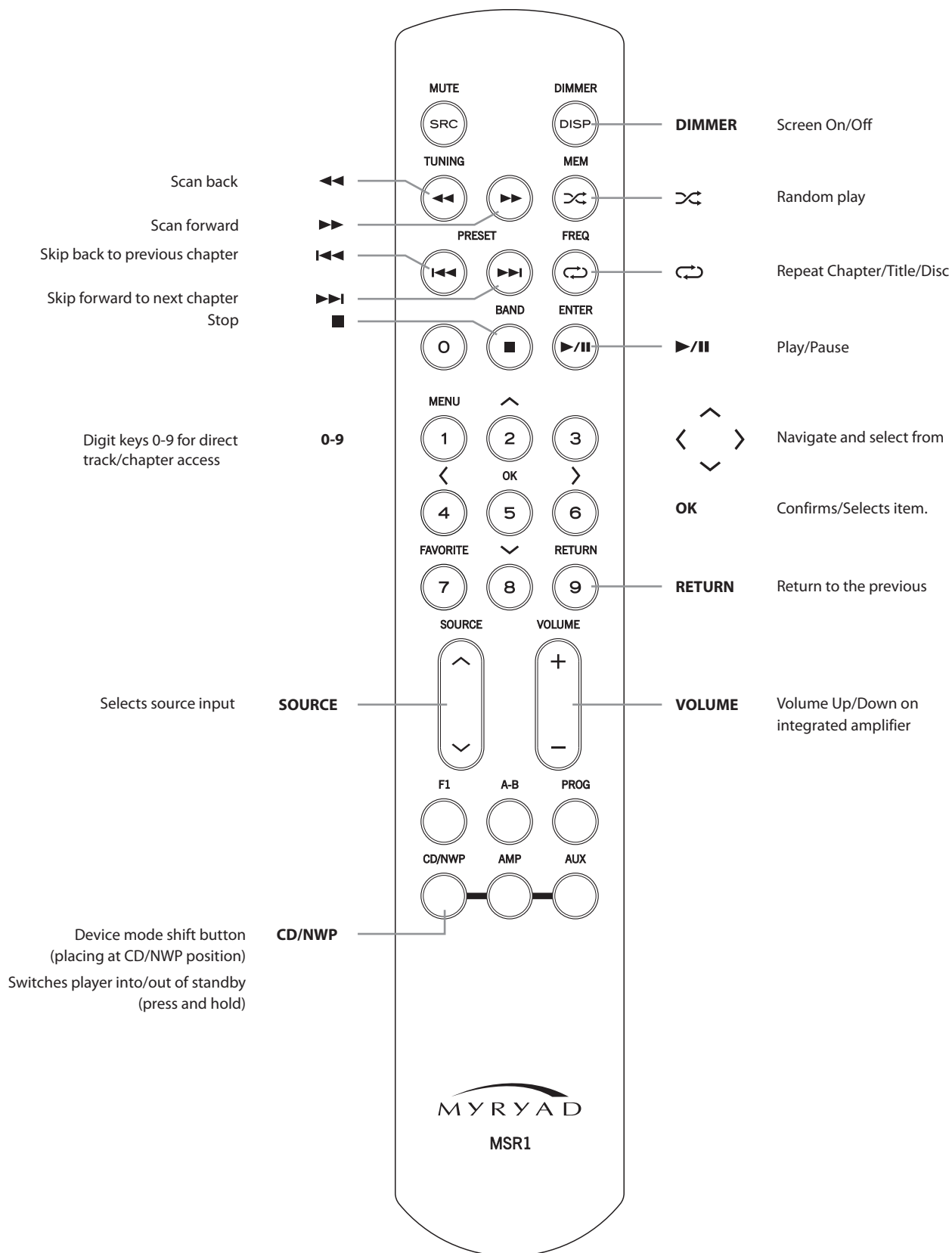

CARE AND HANDLING OF COMPACT DISCS

- Fingerprints and dust should be carefully wiped off the disc's signal surface (shiny side) with a soft cloth. Unlike vinyl records, the CD has no grooves to collect microscopic debris, so gentle wiping with a soft cloth should remove most particles. Wipe in a straight motion from the inside to the outside of the disc. Small dust particles and light stains should have absolutely no effect on reproduction quality.
- Never use chemicals such as record sprays or fluid, benzene or other solvents to clean CDs. Such chemicals will irreparably damage the disc's plastic surface.

- Discs should be returned to their case after use to avoid serious scratches that could cause the laser pickup to skip.
- Do not expose discs to direct sunlight, high humidity or high temperatures for extended periods. Long exposure to high temperatures can warp the disc.
- Do not stick paper or write anything with a ball-point pen on the disc surface.

INSTALLING AND REPLACING BATTERIES

The remote handset uses two 1.5 V type AAA batteries. To fit new batteries first open the battery compartment at the base of the handset and remove any existing batteries. Fit the new ones as directed by the symbols moulded inside the battery compartment, then replace the battery compartment cover.

The batteries should always be removed if they are discharged (indicated by no remote control operation or by operation only at very short range), or if the remote control is not going to be used for an extended period.

TROUBLE-SHOOTING GUIDE

Some of the most common problems:

No sound:

- Power turned off or system in standby mode. Check that the LED by the STANDBY button is illuminated red.
- Amplifier source selection incorrect. Check that CD is selected.

Disc does not PLAY:

- No CD is inserted. Insert a CD, label side up.
- The CD has been loaded upside down. Re-load the disc label side up.
- The CD is badly scratched or dirty. Check the CD and clean or replace as necessary.

The CD skips part of the music:

- The CD is badly scratched or dirty. Check the CD and clean or replace as necessary.

Sound in one channel only:

- Interconnect cable pulled loose or making poor contact. Check and, if necessary, un-plug and re-plug all cables.

Loud buzz or hum:

- Interconnect cable pulled partially out of its socket.
- Defective interconnect cable.

Incorrect operation - some functions not working:

Control processor latched. Switch off POWER on rear panel and wait for at least one minute. Then switch POWER on and switch out of standby. Normal operation should resume.

SPECIFICATIONS

Disc Capacity	120 or 80 mm
Disc formats supported	CD, CD-R, CD-RW
Frequency Response	$<\pm 0.5$ dB (20 Hz–20 kHz)
THD	0.001 % (1kHz)
Signal-to-Noise Ratio	116 dB (A weighted)
Channel Separation	115 dB
Output Level at 0 dB	2.3 Vrms
Output Impedance	5 Ohms
Digital Code Output	Coaxial 75 Ω , to SPDIF standard
Optical Specifications	192 k
USB Specifications	768 kHz/32 bit, DSD512
BT Specifications	Bluetooth 5.0
Dimensions (w x h x d)	436 x 95 x 348 mm
Weight (net)	6.8 kg

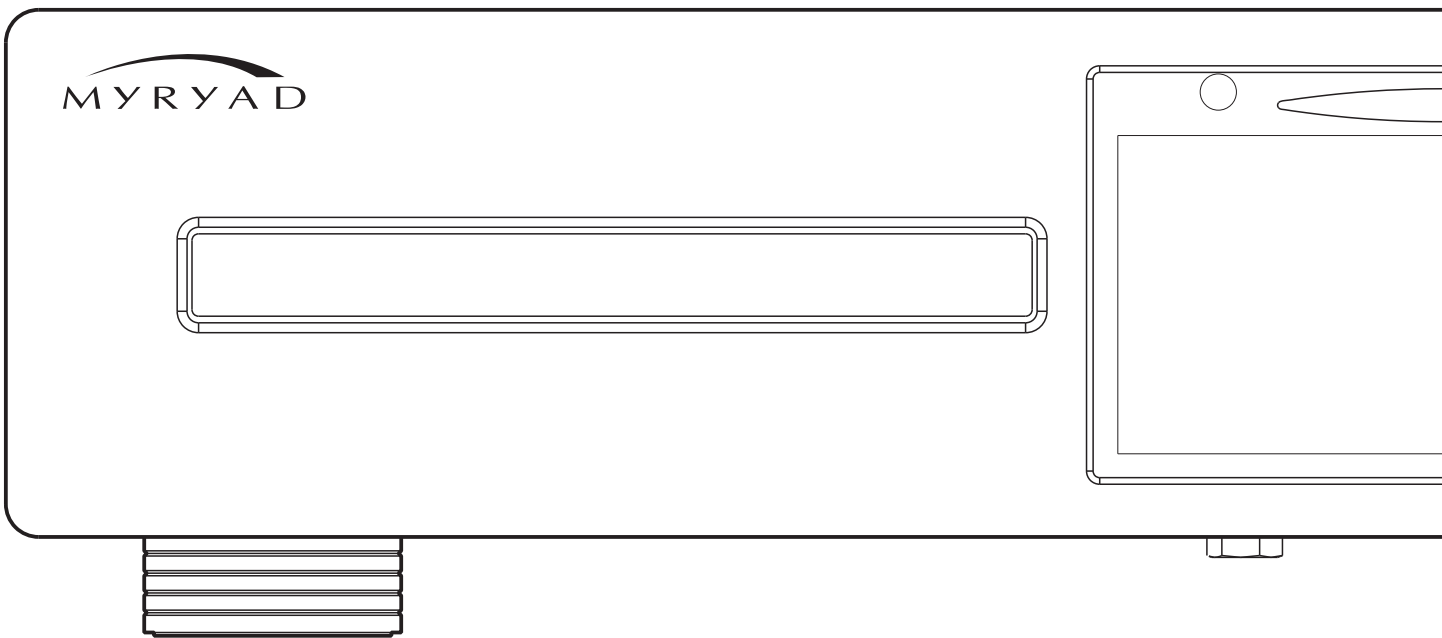

Myryad Systems Ltd.

Our policy is one of continuous product improvement, we reserve the right to change the designs and specifications without notice.

All information is given in good faith. The manufacturer accepts no responsibility for errors, omissions or incorrect assumptions.

	<p>This symbol means do not dispose of as municipal waste. Re-use or recycle wherever possible. Electrical/Electronic Equipment may contain substances harmful to the environment. For environmentally sound methods of disposal, please contact your local government agency.</p>
---	--